

# 38528-TE

## 12V Low Ohm Resistance Tester 0-19.99Ω

Panel mount, 4 Digit LED, Low Ohm resistance Meter

**Power:** 7-12VDC

**Current:** <70mA

**Range:** 0-19.99 KOhms

Accuracy:  $\pm 0.5\%$   $\pm 2\text{LSD}$

**NOTE:** Leads & Connections effect accuracy

**Test Current:** 10mA

Sample Rate:  $\sim 2.5/\text{Sec}$

Display: 4 Digit Red LED.

Character Height: 14.2mm

Temperature Range: 0-50°C

Cutout: 77mm x 39.5mm

**W:** 79mm (3-1/16") **H:** 43mm (1-11/16")

**D:** 25mm (1") O/A **WT:** .12

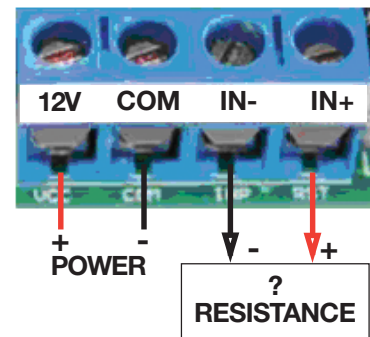
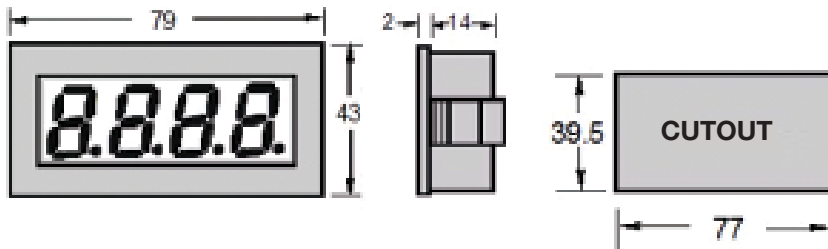

Information including Drawings, Schematics, Links and Code (Software) Supplied or Referenced in this Document is supplied by MPJA inc. as a service to our customers and accuracy or usefulness is not guaranteed nor is it an Endorsement of any particular part, supplier or manufacturer. Use of information and suitability for any application is at users own discretion and user assumes all risk.

Information Subject to Change Without Notice

All rights are retained by the respective Owners/Author(s)



**MARLIN P. JONES & ASSOC., INC.**

8380 Resource Rd. West Palm Beach, FL 33404

800-652-6733 FAX 561-844-8764

WWW.MPJA.COM